

PIC18F24J10.Sch  
 Microchip PIC18F24J10-I/SP Host

MEC1-160-CARD.Sch  
 Interface for SSD1963 EVK Ultima R4.1

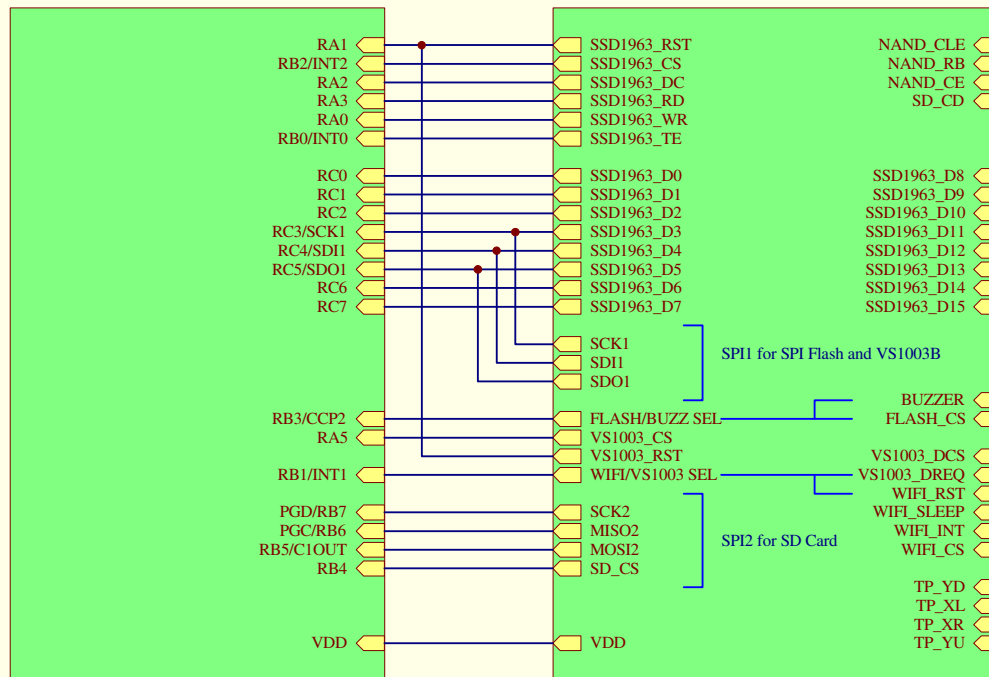

BUZZER & FLASH\_CS selected with jumper J2

VS1003\_DREQ & WIFI\_RST selected with jumper J3  
 \*\*\* WiFi module not connected by default

Block Diagram

Title : EVK PIC28PDIP R1.0		
Size A4		Revision 1.0
Date: 12nd July 2012		Sheet 1 of 3

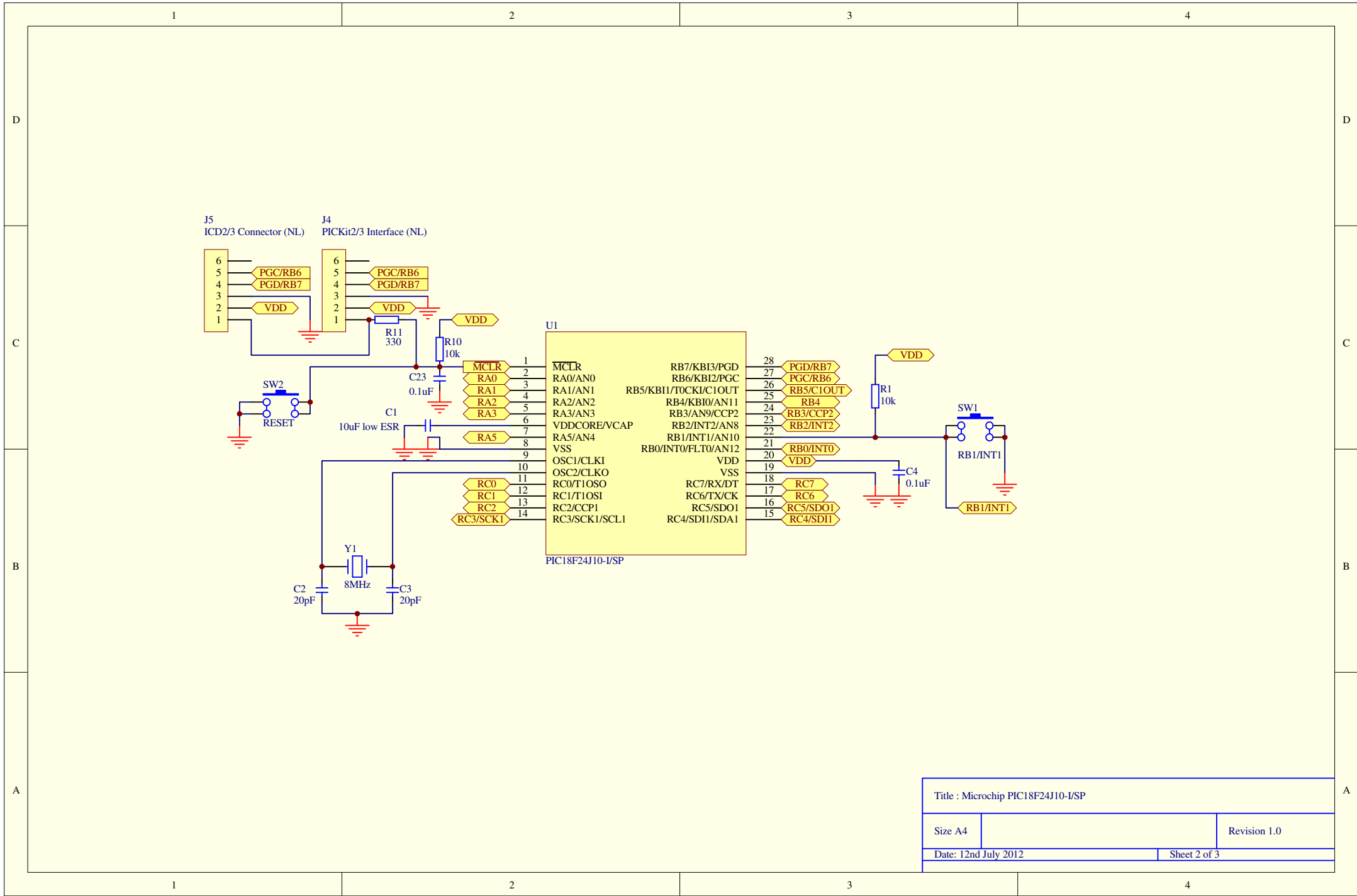

Title : Microchip PIC18F24J10-I/SP	
Size A4	Revision 1.0
Date: 12nd July 2012	Sheet 2 of 3

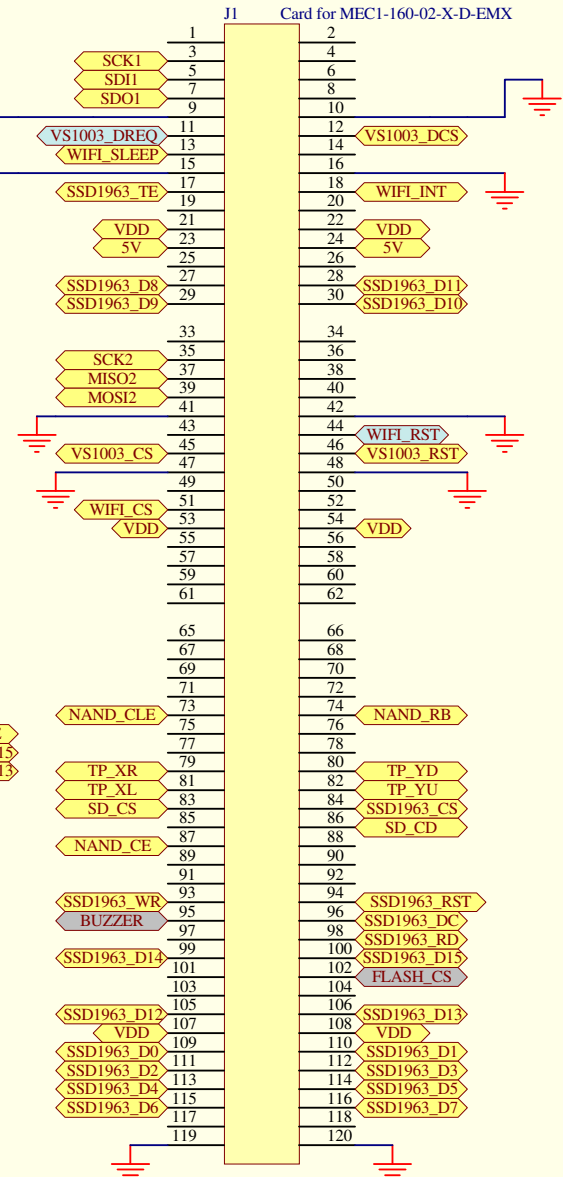
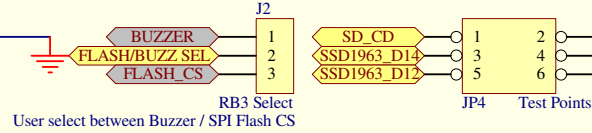
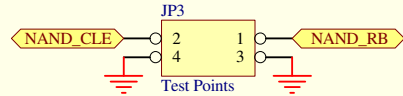
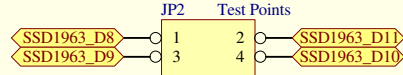
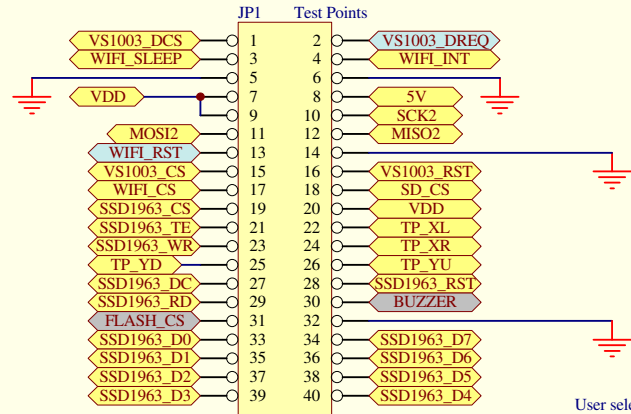
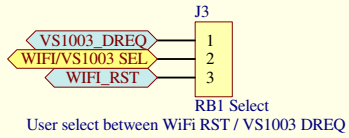

Title : MCU interface and Test Point Arrays		
Size A4		Revision 1.0
Date: 12nd July 2012		Sheet 3 of 3