

Title : Power circuit		
Size : A4	Number :	Revision : 1E
Date : 4-Oct-2010		Sheet of 1/5
File :		

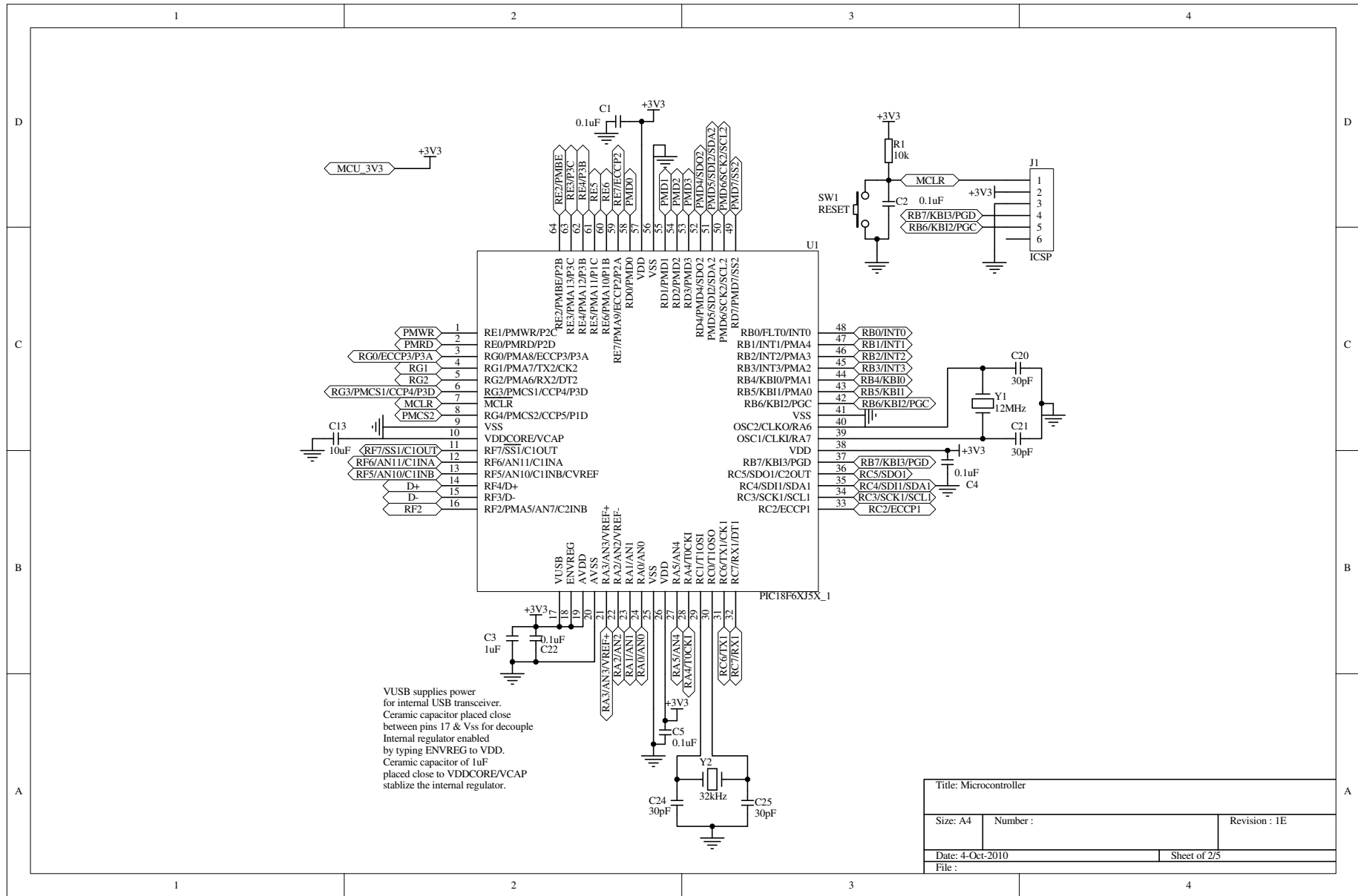

USB supplies power for internal USB transceiver. Ceramic capacitor placed close between pins 17 & Vss for decouple Internal regulator enabled by typing ENVREG to VDD. Ceramic capacitor of 1uF placed close to VDDCORE/VCAP stabilize the internal regulator.

Title: Microcontroller		
Size: A4	Number :	Revision : 1E
Date: 4-Oct-2010	Sheet of 2/5	
File :		

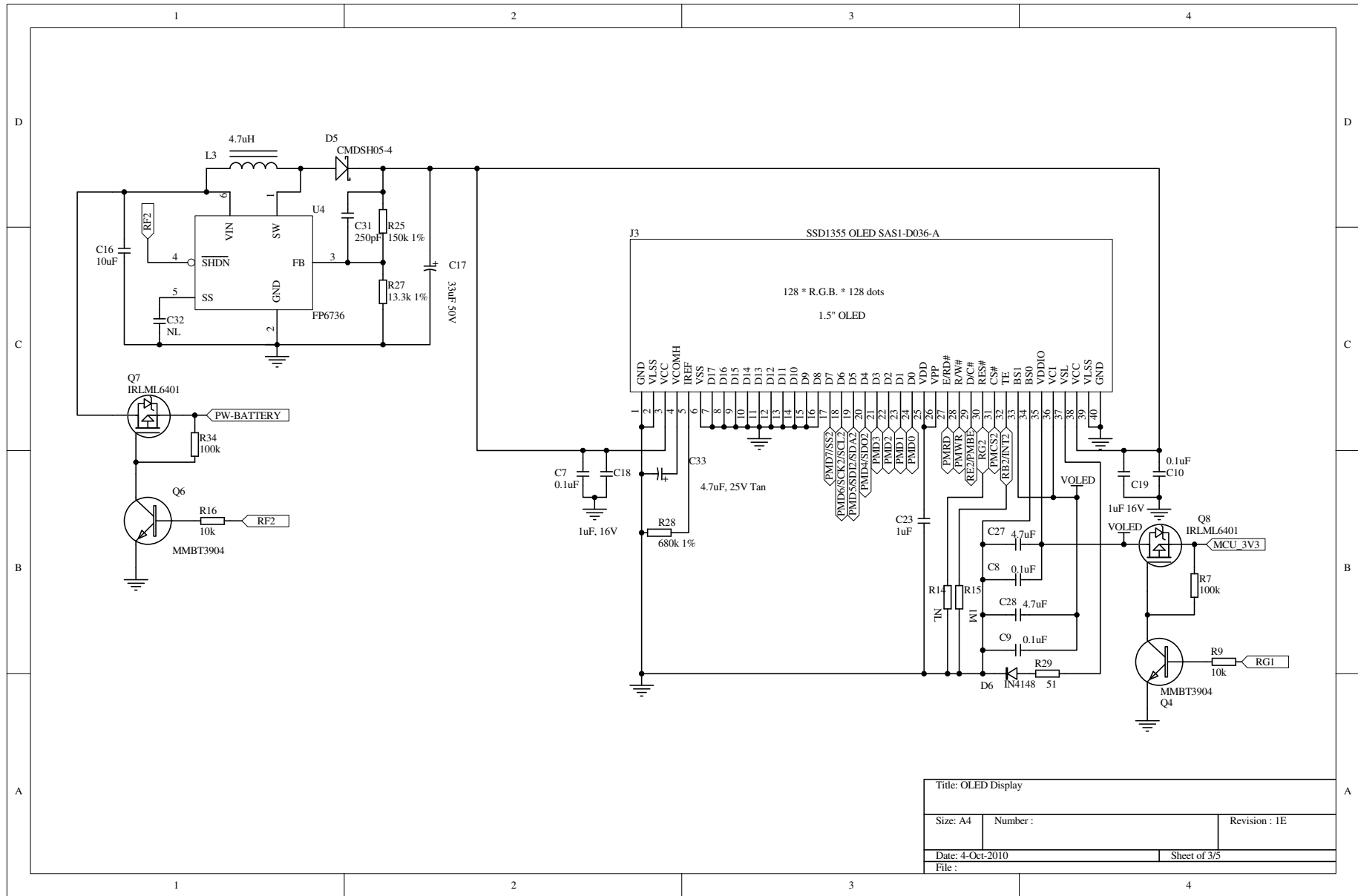

Title: OLED Display		
Size: A4	Number :	Revision : 1E
Date: 4-Oct-2010	Sheet of 3/5	
File :		

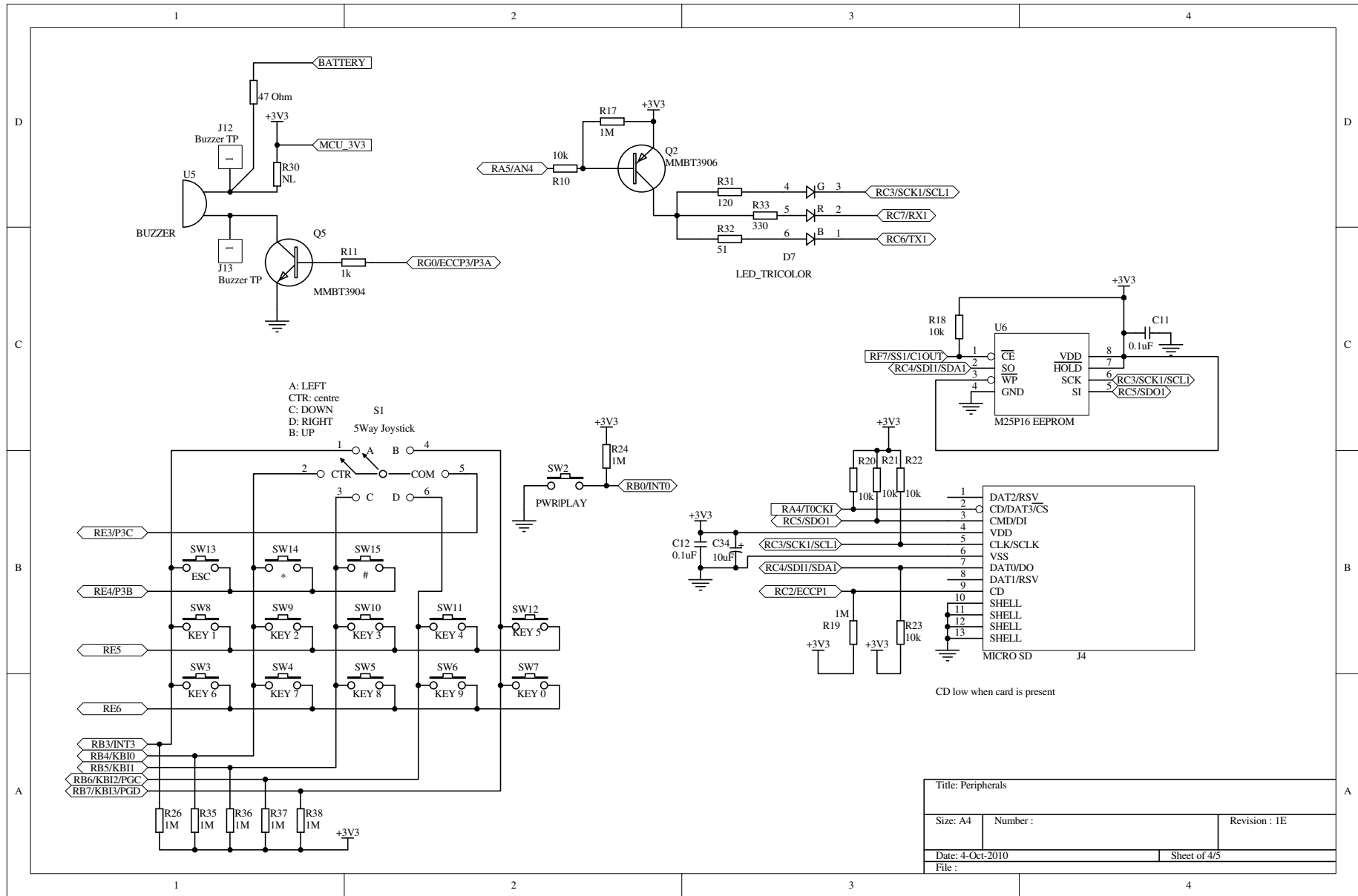

Title: Peripherals		
Size: A4	Number :	Revision : 1E
Date: 4-Oct-2010	Sheet of 4/5	
File :		

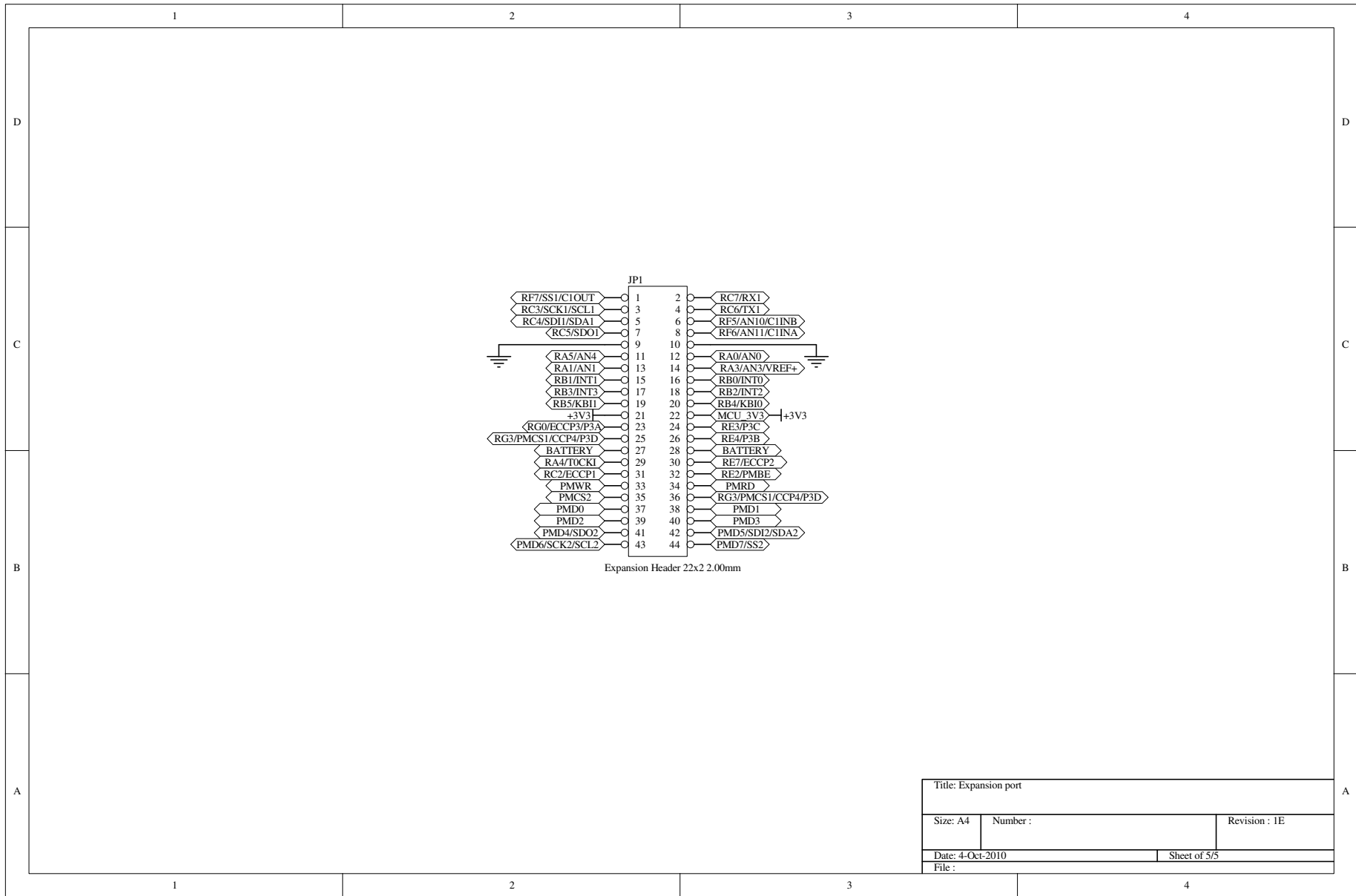

Title: Expansion port		
Size: A4	Number :	Revision : 1E
Date: 4-Oct-2010	Sheet of 5/5	
File :		